

# Data sheet WM4800E-321

4800 lpd (1268 gpd)

With energy recovery system



## AUTOMATED FEATURES:

- User friendly interface with single button operation
- Automatically adjusts to changes in feed water temp. and salinity
- Output for start stop of feed pump
- Input for start-stop on tank level switch
- Automatic fresh water flush system (start/stop, 4 hours/24 hours)
- Shut down at high/low membrane pressure, low/high feed water pressure, high salinity product water
- Integrated timer for setting quiet intervals

## METERS/MONITORS:

- Custom made controller enables close monitoring
- Coloured icons giving continuous overview
- Single button gives access to lot of data:
  - Product water TDS
  - Hour counter
  - Approx. cumulative production
  - Feed/flush water pressure
  - Membrane pressure

## PARTS AND MATERIALS:

- Danfoss APPM2 with integrated energy recovery in duplex and super duplex steel
- Saltwater wetted steel parts in duplex or super duplex steel
- Frame in high quality PEHD polymer
- Overvoltage protection

## OPTIONS:

- GSM based monitoring, control and alarm messaging
- Product water flow measurement

## Data sheet WM4800E-321

Hydraulic Data	50 Hz / 60 Hz
Nominal water production   l/day (gallon/day)	4800 (1268)
Nominal membrane pressure   bar (psi)	55.8 (809) / 55.1 (799)
Total dissolved solids, fresh water (TDS)   mg/l	<550
Stabilized salt rejection   %	99.4
Membrane pressure range   bar (psi)	20-69 (290-1001)
Membrane pressure control	Automatic
Total dissolved solids range, feed water (TDS) <sup>2</sup>   mg/l	1500 – 45000
Minimum inlet flow (feed & flush)   m <sup>3</sup> /h (gallon/h)	1.34 (354) / 1.60 (423)
Minimum flush water volume (3 x flush)   l (gallon)	30 (7.9) / 36 (9.5)
Minimum inlet pressure (feed & flush)   bar (psi)	0.5 (7.3)
Maximum inlet pressure (feed & flush)   bar (psi)	5 (73)
Maximum back pressure on fresh water   bar (psi)	1.0 (14.5)
Nominal pump input power <sup>1</sup>   kW	0.7
Specific pump energy <sup>1</sup>   kWh/m <sup>3</sup> (kWh/1000 gallon)	3.5 (13)

Electrical Data	50 Hz/60 Hz
Motor size – single phase   kW (hp)	1.1 (1.5) / 1.1 (1.5)
Motor size – three phase   kW (hp)	1.1 (1.5) / 1.3 (1.7)
Maximum consumed power – single phase   kW	1.0 / 1.2
Maximum consumed power – three phase   kW	0.9 / 1.0
Motor voltage   V	1 ph: 230, 3 ph: 230/208-280-Δ or 400/480-Y
Motor speed (50/60 Hz grid)   rpm	1450 / 1740
Feed pump control	Relay output
Water level signal	Relay input
Electrical ingress protection	IP 54

Dimensions	
Watermaker (LxWxH)   mm (inch)	734x400x412 (29x16x16)
Control box (LxWxH)   mm (inch)	392x200x155 (12x8x6)
Water inlet/outlet (OD)   mm (inch)	22 (0.9)
Weight   kg (lb)	44 (97)

Operating limits	
Feed water temperature <sup>2</sup>   °C (°F)	0.5 – 45 (32.9 – 113)
Ambient temperature   °C (°F)	0.5 – 50 (32.9 – 122)

Components	
Membrane type	DOW/AqSep seawater
Membrane quantity	3
Membrane size   Inches	3x21
High pressure pump & recovery unit	APPM2 - Duplex steel
Lubrication, coolants etc.	Not required
Frame	Plastic, 316 steel
Saltwater exposed parts	Duplex/316 steel, plastic
Fresh water parts	316 steel, brass, plastic
Controller	Custom made with display (GSM interface as option)

Part Number <sup>3</sup>	
WM4800E-321 1x230 V, 60 Hz, 1700 rpm	182B0010
WM4800E-321 3x208 V, 60 Hz, 1700 rpm	182B0009
WM4800E-321 3x480 V, 60 Hz, 1700 rpm	182B0011
WM4800E-321 1x230 V, 50 Hz, 1400 rpm	182B0012
WM4800E-321 3x400 V, 50 Hz, 1400 rpm	182B0013

Rated performance may vary ±15%, Nominal conditions: 25 °C seawater at 32.000 mg/l TDS

<sup>1</sup> Based on simulation in ROSA design software from Dow Water & Process Solutions

<sup>2</sup> Depending on feed water temperature/amount of feed water solids (TDS)

<sup>3</sup> Contact AqSep for alternative motor voltages/frequencies

## Data sheet WM4800E-321

mm (inch)

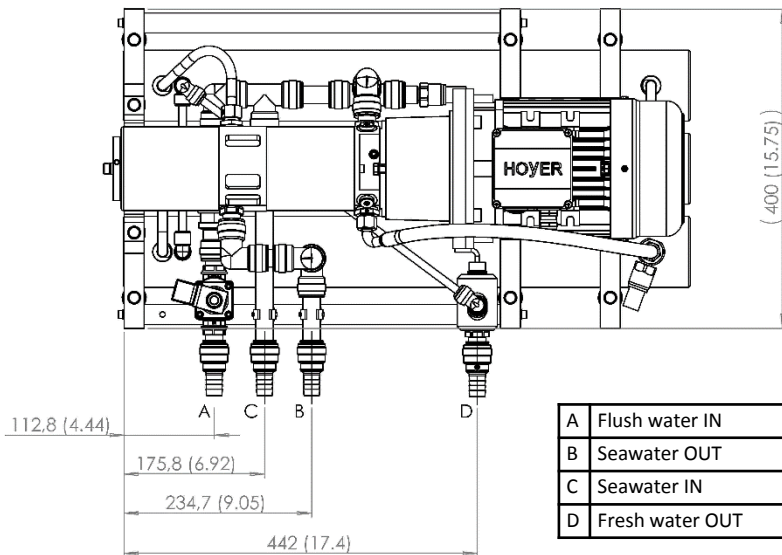
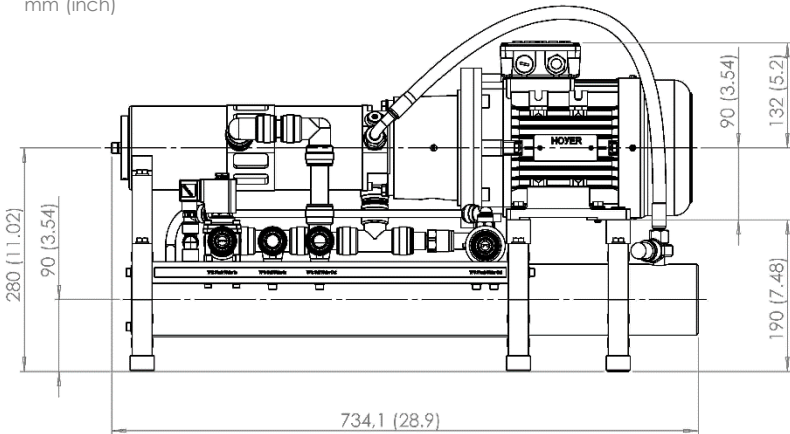

A	Flush water IN
B	Seawater OUT
C	Seawater IN
D	Fresh water OUT

## Control Box

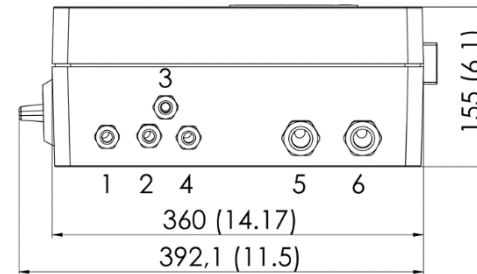

1	Power Connection
2	Electrical motor
3	Solenoid valve
4	Cable tree – sensors
5	Feed pump signal – XS1
6	Level switch signal – XS2

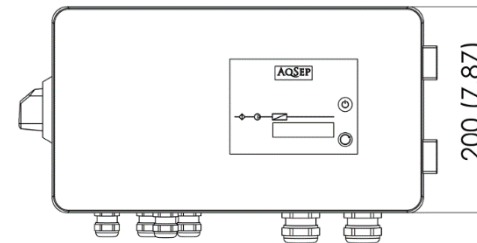

The control box is connected to the sensors on the hydraulic unit via a cable tree of 3 m (9.9 ft.). Separate cables connects the electrical motor and valve.

Mating electrical connectors for start & stop of well pump/isolating valve as well as level switch signal are located inside the control box.

The optional GSM modem is also fitted to the control box.

## AqSep A/S

c/o Danfoss • Nordborgvej 81, E14-N14 • 6430 Nordborg • Denmark  
 Phone: +45 7488 4100 • E-mail: anders@aqsep.com • www.aqsep.com

AqSep can accept no responsibility for possible errors in catalogues, brochures and other printed material. AqSep reserves the right to alter its products without notice. This also applies to products already on order provided that such alterations can be made without sub sequential changes being necessary in specifications already agreed. All AqSep trademarks in this material are property of AqSep. AqSep and the AqSep logotype are trademarks of AqSep A/S. All rights reserved.